



'BUILT TOUGH, PROVEN TOUGH'



SMART TANK
15,000L

SPEC SHEET

Size	Safe Fill (L)	Weight (kg)	Length (mm)	Width (mm)	Height (mm)
15,000L	13,500	4200	6000	2400	1500

Standard Features:

- Designed and manufactured in Australia to Australian Standards
- Self bunded (double wall)
- Manway for access to inner tank
- Fork Lift Pockets and Under tank visibility for visual inspection
- 2" Bulk fill point with Overfill protection valve and alarm.
- 4 Lift points for easy moving and transportation (whilst Empty only)
- Calibrated dipstick with safe fill level, located in a Lockable Spill Box
- Domed roof to stop water/dirt pooling
- Safety signage for Australian regulations
- Lockable Pump bay with container style doors and locks.

Optional Pumps:

- 240v Pump
- Diesel or Petrol Driven Pumps
- Ebsray Pumps
- Regent Pumps

Have a pump you want? let the team know

Optional Accessories:

- 10m, 20m or 30m Heavy Duty Retractable Hose Reel
- 1-10m Loose Hose
- Emergency Stop, Battery Isolator and Reflective Mine Tape
- High Mast Assembly
- LED Light Kits
- Fuel Management Systems
- Reconnectable Breakaway Coupling
- Ocio Tank Level Gauge
- Spill Kits & Fire Extinguishers
- 250T Drive Over Spill Grate
- Credit Card Reader (24/7 public sites)
- Auto Shutoff Nozzle
- Wiggins Nozzle



ENGINEERING SPECIFICATIONS:

1. MATERIAL SPECIFICATION
 - FLAT: GRADE 300+ AS/NZS 3679.1
 - PLATE/ SHEET: GRADE 250 AS 3678
 - PFC: GRADE 300+ AS/NZS 3679.1
 - R/BAR: GRADE 300+ AS/NZS 3679.1
 - ALL FLANGES ANSI 150
 - ALL VALVES FIRE SAFE CARBON STEEL
 2. DESIGN COMPLIANCE
 - ADG CODE 7th EDITION
 - AS1940-2017: STORAGE AND HANDLING OF FLAMMABLE AND COMBUSTIBLE LIQUIDS
 - AS1692-2006: STEEL TANK FOR FLAMMABLE AND COMBUSTIBLE LIQUIDS
 - FUEL TANK IS DEFINED AS CATEGORY 3, WITH COMBUSTIBLE LIQUID
 - BUNDED 'DOUBLE SKIN' DESIGN
- DIMENSIONAL AND MATERIAL SPECIFICATIONS WITHIN FOLLOWING DRAWINGS SET NEED TO BE MAINTAINED AND TO MEET COMPLIANCE
- THE DESIGNED SAFE FILL LEVEL (SFL) IS 13,500L
 - FUEL TANK ASSEMBLY WEIGHT
 - EMPTY: 3,980kg
 - FILLED: 15,180kg

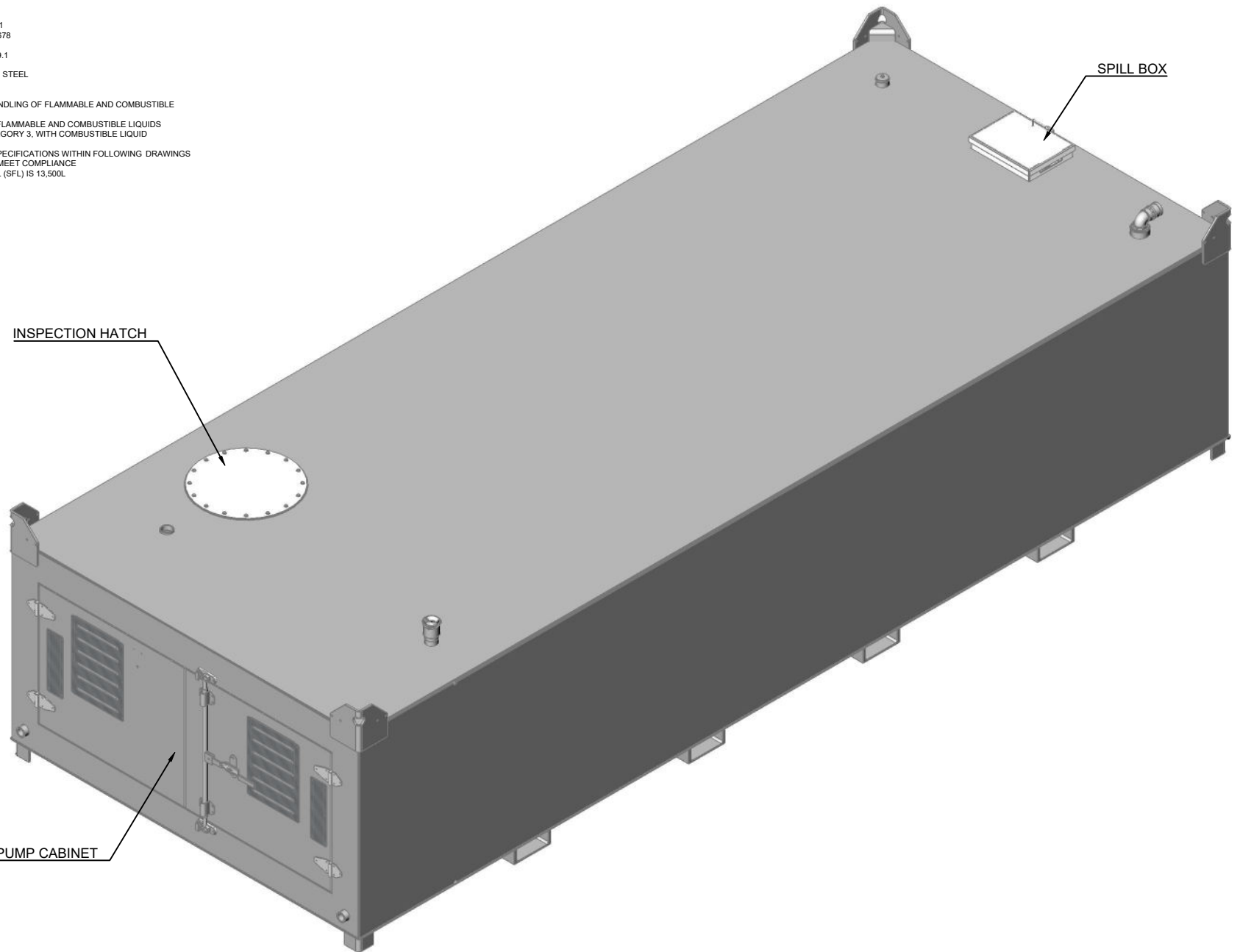

INSPECTION HATCH

SPILL BOX

LOCKABLE PUMP CABINET

A
B
C
D
E
F

A
B
C
D
E
F

REV	DATE	DETAILS	BY	APPD

GENERAL NOTES
 ALL DIMENSIONS ARE IN MILLIMETERS (mm) U.N.O
 GENERAL TOLERANCE U.N.O
 X ±0.5
 XX ±0.1
 XXX ±0.05
 Angular ±0.25°
 REMOVE ALL SHARP EDGES AND BURRS
 PAINTING MANUFACTURER IN ACCORDANCE
 MATERIAL GR250
 2 West St, Lake Cargelligo NSW 2672
 Phone: 1300 629 802
 Email: sales@durotank.com.au
 Web: www.durotank.com.au



 THIRD ANGLE PROJECTION 1:5 STANDARD FINISH REF: 20/20	TITLE	
	OVERVIEW	
DRN: MWH	SHEET	DWG
DATE: 18.05.2022	A3	ST015
CHK:	NO:	DO NOT SCALE U.N.O
		PAGE 01 OF 02

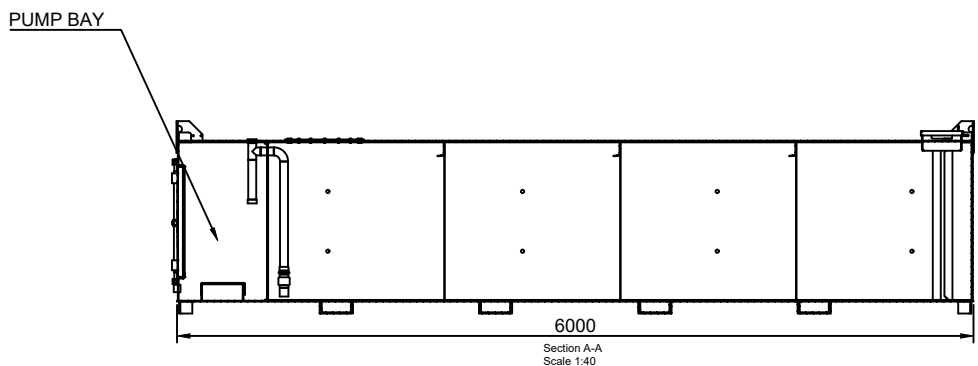
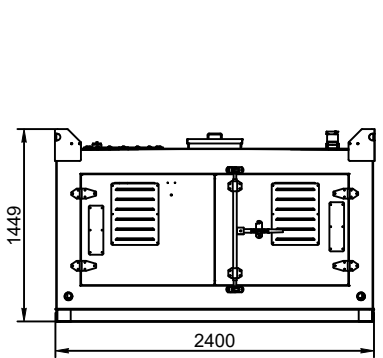
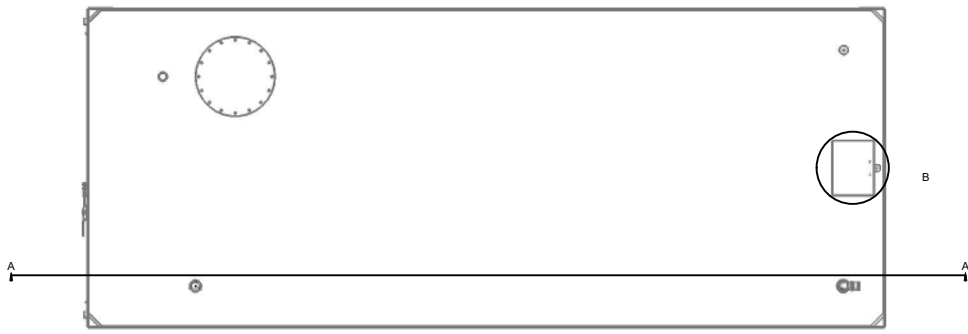
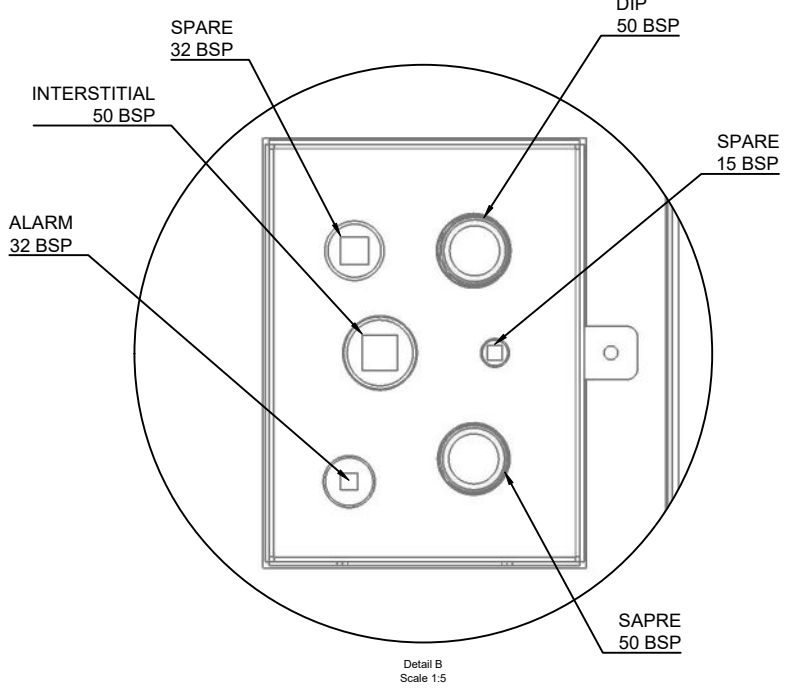
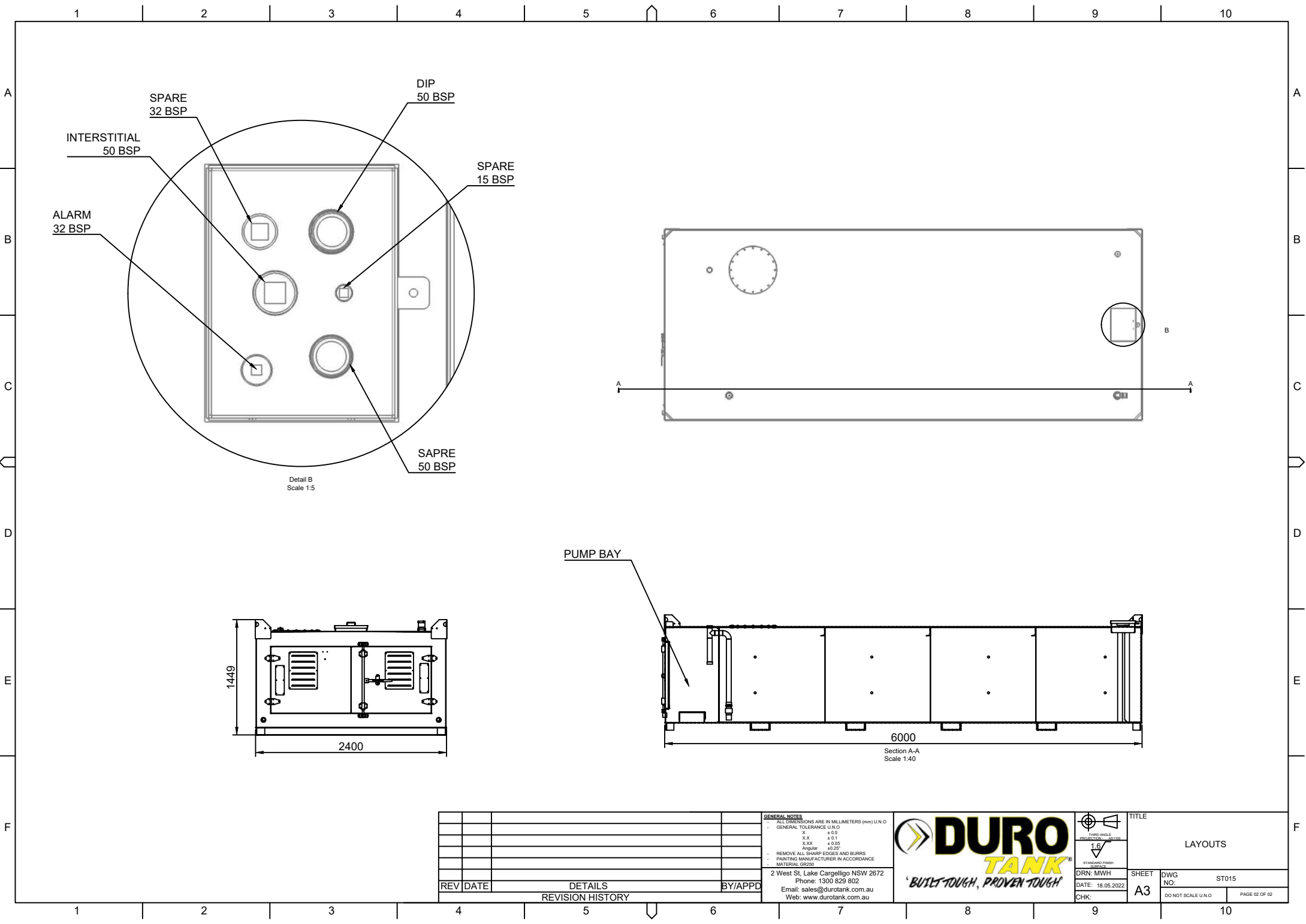

REV	DATE	DETAILS	BY/APPD
REVISION HISTORY			

GENERAL NOTES
 ALL DIMENSIONS ARE IN MILLIMETERS (mm) U.N.O
 GENERAL TOLERANCE U.N.O
 X ± 0.5
 XX ± 0.1
 XXX ± 0.05
 Angular ± 0.25°
 REMOVE ALL SHARP EDGES AND BURRS
 PAINTING MANUFACTURER IN ACCORDANCE
 MATERIAL GR250
 2 West St, Lake Cargelligo NSW 2672
 Phone: 1300 629 802
 Email: sales@durotank.com.au
 Web: www.durotank.com.au



 THIRD ANGLE PROJECTED 1:5 STANDAARD FINISH REF. 2.2.10 DRN: MWH DATE: 18.05.2022 CHK:	TITLE LAYOUTS SHEET A3 DWG NO: ST015 DO NOT SCALE U.N.O PAGE 02 OF 02
--	--