



'BUILT TOUGH, PROVEN TOUGH'



**Smart Cube
5,000L**

SPEC SHEET

Size	Safe Fill (L)	Weight (kg)	Length (mm)	Width (mm)	Height (mm)
5,000L	5,000L	1210	2400	2000	1500

Standard Features:

- Designed and manufactured in Australia to Australian Standards
- Self bunded (double wall)
- Manway for access to inner tank
- Fork Lift Pockets and Under tank visibility for visual inspection
- Full load rated lifting brackets
- Stackable whilst empty
- 4 Lift points for easy moving and transportation
- Calibrated dipstick with safe fill level, located in a Lockable Spill Box
- Safety signage for Australian regulations

Optional Pumps:

- 12v/24v Pump (with or without Solar Battery kit)
- 240v Pump
- Diesel or Petrol Driven Pumps
- Ebsray Pumps
- Regent Pumps

Optional Accessories:

- 10m, 20m or 30m Heavy Duty Retractable Hose Reel
- 1-10m Loose Hose
- Emergency Stop, Battery Isolator and Reflective Mine Tape
- High Mast Assembly
- LED Light Kits
- Fuel Management Systems
- Reconnectable Breakaway Coupling
- Ocio Tank Level Gauge
- Spill Kits & Fire Extinguishers
- 250T Drive Over Spill Grate
- Credit Card Reader (24/7 public sites)
- Auto Shutoff Nozzle
- Wiggins Nozzle
- Single or Dual door pump cabinets



ENGINEERING SPECIFICATIONS:

1. MATERIAL SPECIFICATION
 - FLAT: GRADE 300+ AS/NZS 3679.1
 - PLATE/ SHEET: GRADE 250 AS 3678
 - PFC: GRADE 300+ AS/NZS 3679.1
 - R/BAR: GRADE 300+ AS/NZS 3679.1
 - ALL FLANGES ANSI 150
 - ALL VALVES FIRE SAFE CARBON STEEL
 2. DESIGN COMPLIANCE
 - ADG CODE 7th EDITION
 - AS1940-2017: STORAGE AND HANDLING OF FLAMMABLE AND COMBUSTIBLE LIQUIDS
 - AS1692-2006: STEEL TANK FOR FLAMMABLE AND COMBUSTIBLE LIQUIDS
 - FUEL TANK IS DEFINED AS CATEGORY 3, WITH COMBUSTIBLE LIQUID
 - BUNDED 'DOUBLE SKIN' DESIGN
- DIMENSIONAL AND MATERIAL SPECIFICATIONS WITHIN FOLLOWING DRAWINGS SET NEED TO BE MAINTAINED AND TO MEET COMPLIANCE
- THE DESIGNED SAFE FILL LEVEL (SFL) IS 5,000L
 - FUEL TANK ASSEMBLY WEIGHT
 - EMPTY: 1,290kg
 - FILLED: 5,450kg

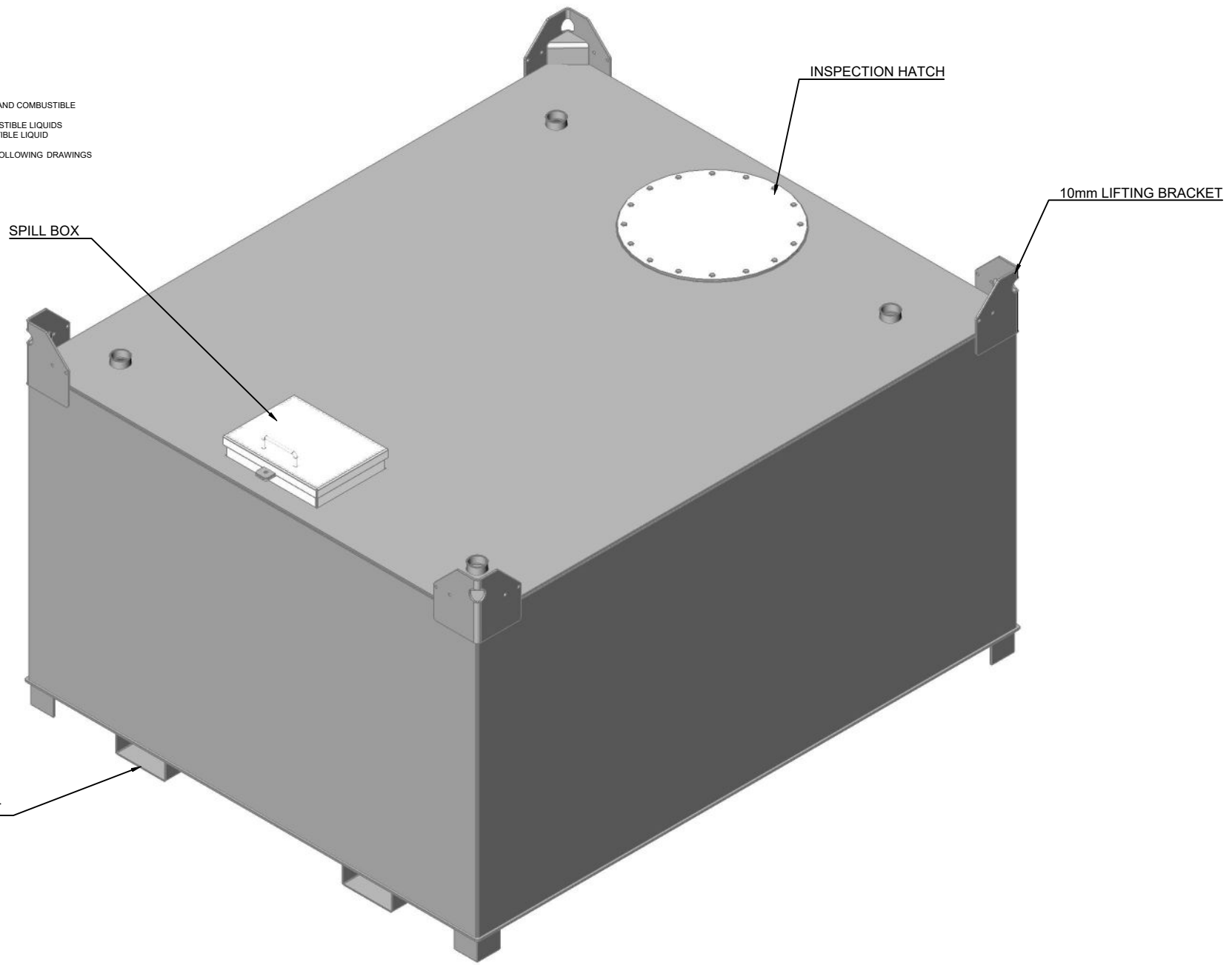

REV	DATE	DETAILS	BY	APPD

GENERAL NOTES
 ALL DIMENSIONS ARE IN MILLIMETERS (mm) U.N.O
 GENERAL TOLERANCE U.N.O
 X ± 0.5
 XX ± 0.1
 XXX ± 0.05
 Angular ± 0.25°
 REMOVE ALL SHARP EDGES AND BURRS
 PAINTING MANUFACTURER IN ACCORDANCE
 MATERIAL GR250
 2 West St, Lake Cargelligo NSW 2672
 Phone: 1300 629 802
 Email: sales@durotank.com.au
 Web: www.durotank.com.au



 THIRD ANGLE PROJECTION 1:5 STANDARD FINISH 250°C/250	TITLE OVERVIEW
DRN: MWH DATE: 25.05.2021 CHK:	SHEET A3 DWG NO: SC050 DO NOT SCALE U.N.O PAGE 01 OF 02

1 2 3 4 5 6 7 8 9 10

A

B

C

D

E

F

A

B

C

D

E

F

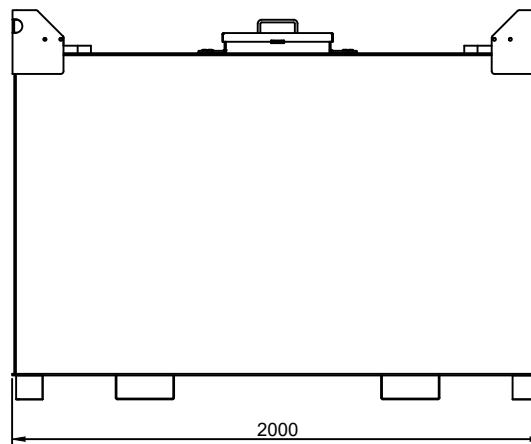
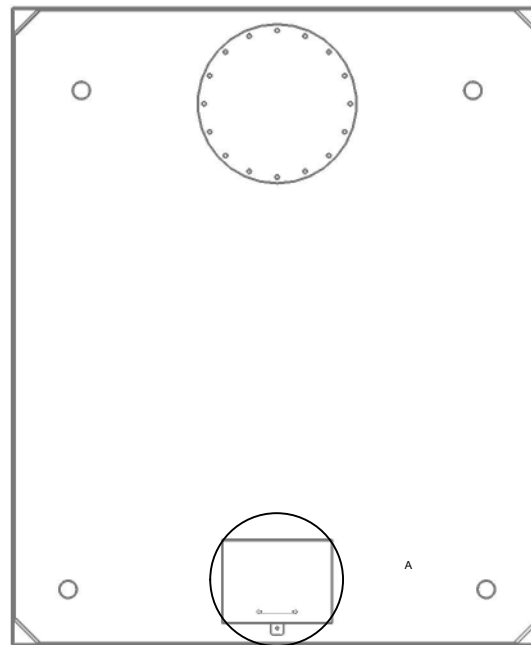
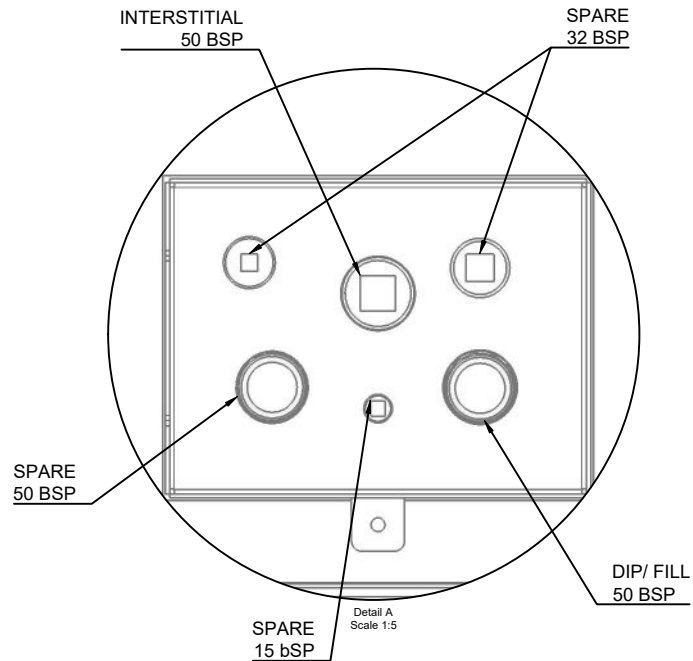

REV	DATE	DETAILS	BY/APPD

GENERAL NOTES
 ALL DIMENSIONS ARE IN MILLIMETERS (mm) U.N.O
 GENERAL TOLERANCE U.N.O
 X ± 0.5
 X.X ± 0.1
 X.XX ± 0.05
 Angular ± 0.25°
 REMOVE ALL SHARP EDGES AND BURRS
 PAINTING MANUFACTURER IN ACCORDANCE
 MATERIAL GR250

2 West St, Lake Cargelligo NSW 2672
 Phone: 1300 629 802
 Email: sales@durotank.com.au
 Web: www.durotank.com.au



 1:5 STANDARD FINISH 250/250/250	TITLE LAYOUTS	
DRN: MWH DATE: 25.05.2021 CHK:	SHEET NO: A3	DWG NO: SC050 DO NOT SCALE U.N.O PAGE 02 OF 02

1 2 3 4 5 6 7 8 9 10