

DURO **TANK**[®]

'BUILT TOUGH, PROVEN TOUGH'



Duro Cube
3,000L

SPEC SHEET

Size	Safe Fill (L)	Weight (kg)	Length (mm)	Width (mm)	Height (mm)
3,000L	3,000L	1350	2200	1600	1500

Standard Features:

- Designed and manufactured in Australia to Australian Standards
- Self bunded (double wall)
- Manway for access to inner tank
- Fork Lift Pockets and Under tank visibility for visual inspection
- Internally baffled for stability of liquid while transporting.
- Stackable whilst full
- 4 Lift points for easy moving and transportation, rated to lift whilst full
- Calibrated dipstick with safe fill level, located in a Lockable Spill Box
- Safety signage for Australian regulations

Optional Pumps:

- 12v/24v Pump (with or without Solar Battery kit)
- 240v Pump
- Diesel or Petrol Driven Pumps
- Ebsray Pumps
- Regent Pumps

Optional Accessories:

- 10m, 20m or 30m Heavy Duty Retractable Hose Reel
- 1-10m Loose Hose
- Emergency Stop, Battery Isolator and Reflective Mine Tape
- High Mast Assembly
- LED Light Kits
- Fuel Management Systems
- Reconnectable Breakaway Coupling
- Ocio Tank Level Gauge
- Spill Kits & Fire Extinguishers
- 250T Drive Over Spill Grate
- Credit Card Reader (24/7 public sites)
- Auto Shutoff Nozzle
- Wiggins Nozzle
- Single or Dual door pump cabinets



1 2 3 4 5 6 7 8 9 10

ENGINEERING SPECIFICATIONS:

- MATERIAL SPECIFICATION**
 - FLAT: GRADE 300+ AS/NZS 3679.1
 - PLATE/ SHEET: GRADE 250 AS 3678
 - PFC: GRADE 300+ AS/NZS 3679.1
 - R/BAR: GRADE 300+ AS/NZS 3679.1
 - ALL FLANGES ANSI 150
 - ALL VALVES FIRE SAFE CARBON STEEL
 - DESIGN COMPLIANCE**
 - ADG CODE 7th EDITION
 - AS1940-2017: STORAGE AND HANDLING OF FLAMMABLE AND COMBUSTIBLE LIQUIDS
 - AS1692-2006: STEEL TANK FOR FLAMMABLE AND COMBUSTIBLE LIQUIDS
 - FUEL TANK IS DEFINED AS CATEGORY 3, WITH COMBUSTIBLE LIQUID
 - BONDED 'DOUBLE SKIN' DESIGN
- DIMENSIONAL AND MATERIAL SPECIFICATIONS WITHIN FOLLOWING DRAWINGS SET NEED TO BE MAINTAINED AND TO MEET COMPLIANCE
- THE DESIGNED SAFE FILL LEVEL (SFL) IS
 - FUEL TANK ASSEMBLY WEIGHT
 - EMPTY: 1,010kg
 - FILLED: 3,500kg

A
B
C
D
E
F

A
B
C
D
E
F

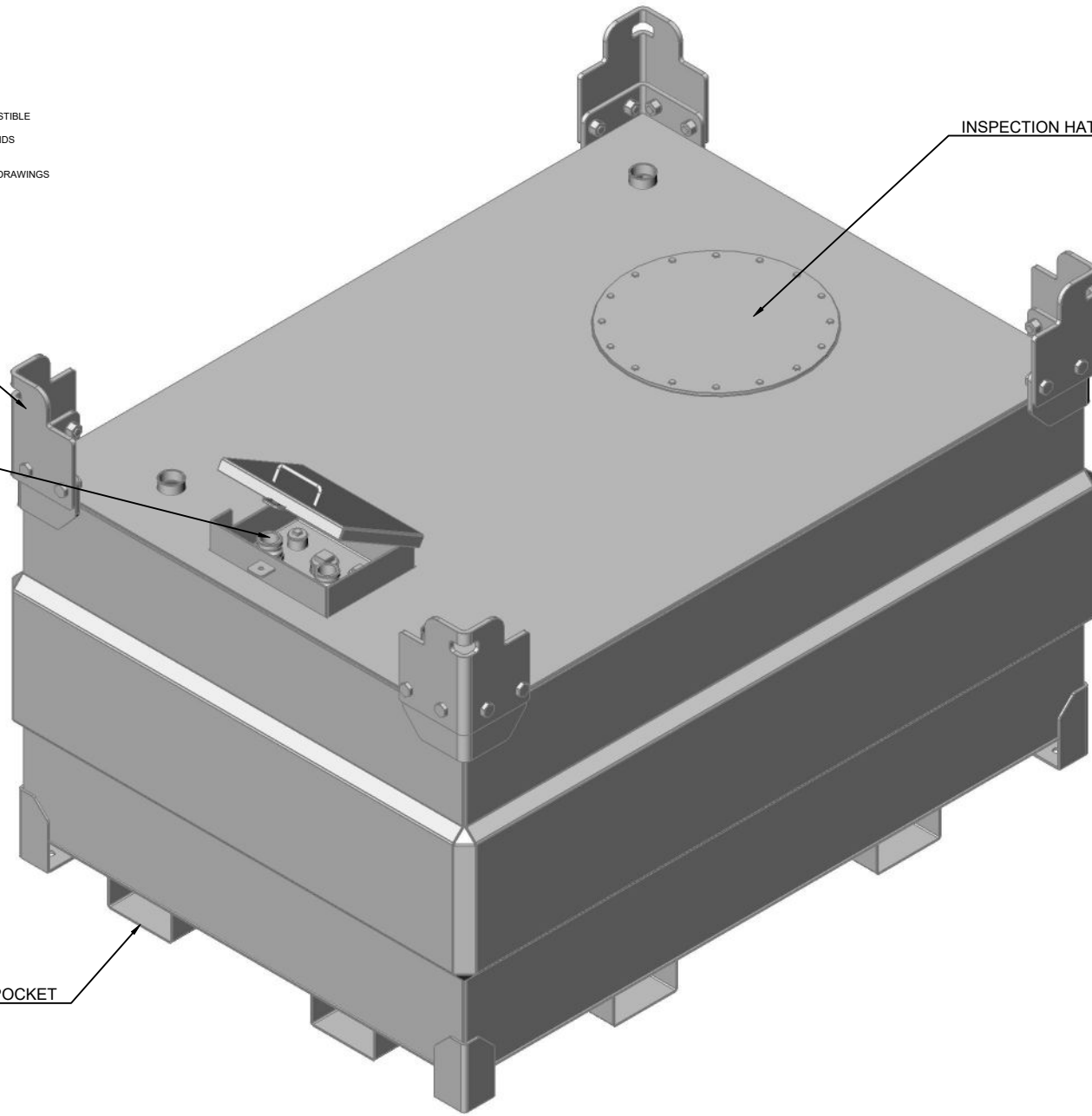

INSPECTION HATCH

12mm LIFTING LUG

SPILL BOX

FORKLIFT POCKET

REV	DATE	DETAILS	BY	APPD

REVISION HISTORY

GENERAL NOTES
 ALL DIMENSIONS ARE IN MILLIMETERS (mm) U.N.O
 - GENERAL TOLERANCE U.N.O
 X ± 0.25
 X.X ± 0.1
 X.XX ± 0.05
 Angular ± 0.25°
 - REMOVE ALL SHARP EDGES AND BURRS
 - PAINTING MANUFACTURER IN ACCORDANCE
 - MATERIAL GR250

DURO TANK
 DURABILITY BUILT TO LAST

114-116 Canada St. Lake Cargelligo NSW 2672
 Phone: 1300 829 802
 Fax: 1300 259 659

TITLE
 OVERVIEW

DRN: MWH SHEET: A3
 DATE: 02.03.2020 DWG NO: DC030
 CHK: DO NOT SCALE U.N.O PAGE 02 OF 00

1 2 3 4 5 6 7 8 9 10

A

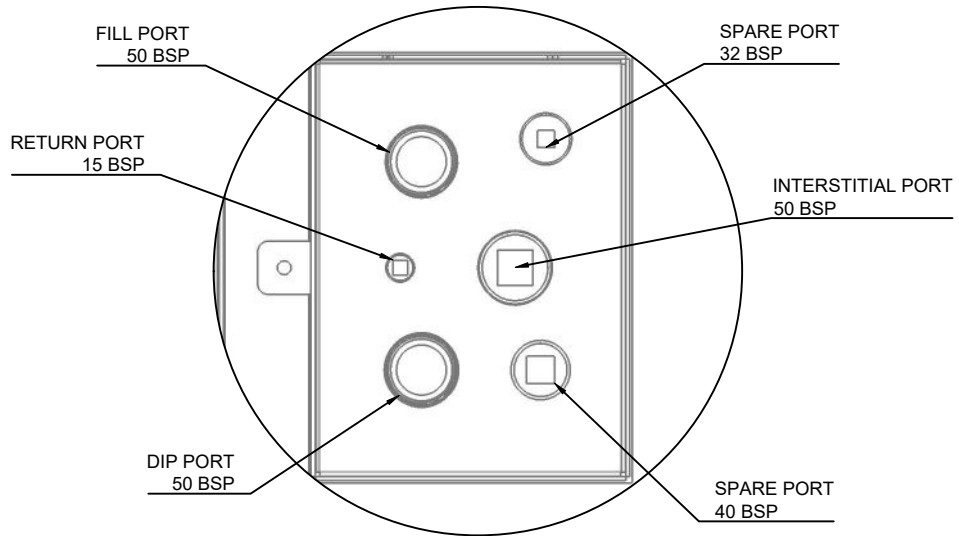

Detail B
Scale 1:5

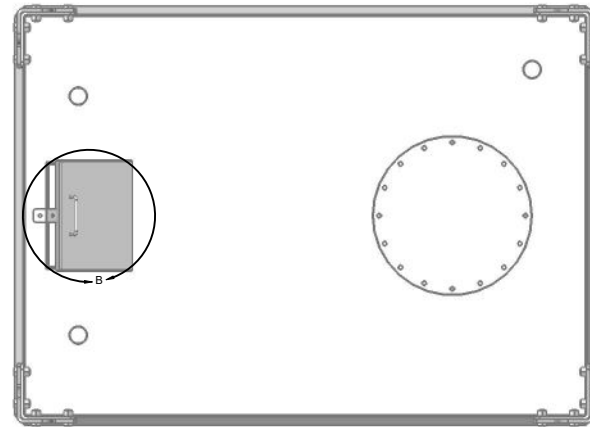

B

C

D

E

F

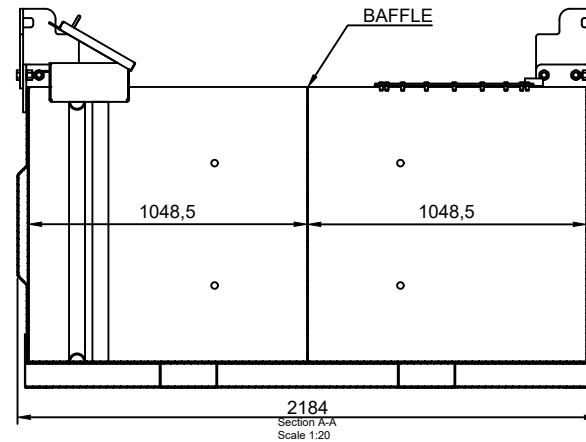
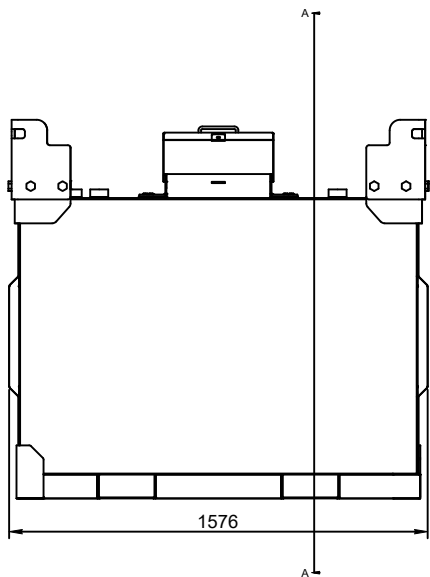

REV	DATE	DETAILS	BY/APPD

GENERAL NOTES
 ALL DIMENSIONS ARE IN MILLIMETERS (mm) U.N.O.
 GENERAL TOLERANCE U.N.O
 X ± 0,5
 X.X ± 0,1
 X.XX ± 0,05
 Angular ± 0,25°
 REMOVE ALL SHARP EDGES AND BURRS
 PAINTING MANUFACTURER IN ACCORDANCE
 MATERIAL GR250



114-116 Canada St. Lake Cargelligo NSW 2672
 Phone: 1300 829 802
 Fax: 1300 259 659

STANDARD MESH
 1/2" x 1/2" x 3/16"
 DRN: MWH
 DATE: 02.03.2020
 CHK:

TITLE		SHEET		DWG	
DC030 LAYOUTS		A3		DC030	
NO:		NO:		PAGE 02 OF 02	