



DURO **TANK**[®]

'BUILT TOUGH, PROVEN TOUGH'



Duro Cube
2,000L

SPEC SHEET

| Size | Safe Fill (L) | Weight (kg) | Length (mm) | Width (mm) | Height (mm) |
|--------|---------------|-------------|-------------|------------|-------------|
| 2,000L | 2,000L | 995 | 2200 | 1140 | 1500 |

Standard Features:

- Designed and manufactured in Australia to Australian Standards
- Self bunded (double wall)
- Manway for access to inner tank
- Fork Lift Pockets and Under tank visibility for visual inspection
- Internally baffled for stability of liquid while transporting.
- Stackable whilst full
- 4 Lift points for easy moving and transportation, rated to lift whilst full
- Calibrated dipstick with safe fill level, located in a Lockable Spill Box
- Safety signage for Australian regulations

Optional Pumps:

- 12v/24v Pump (with or without Solar Battery kit)
- 240v Pump
- Diesel or Petrol Driven Pumps
- Ebsray Pumps
- Regent Pumps

Optional Accessories:

- 10m, 20m or 30m Heavy Duty Retractable Hose Reel
- 1-10m Loose Hose
- Emergency Stop, Battery Isolator and Reflective Mine Tape
- High Mast Assembly
- LED Light Kits
- Fuel Management Systems
- Reconnectable Breakaway Coupling
- Ocio Tank Level Gauge
- Spill Kits & Fire Extinguishers
- 250T Drive Over Spill Grate
- Credit Card Reader (24/7 public sites)
- Auto Shutoff Nozzle
- Wiggins Nozzle
- Single or Dual door pump cabinets



ENGINEERING SPECIFICATIONS:

1. MATERIAL SPECIFICATION
 - FLAT: GRADE 300+ AS/NZS 3679.1
 - PLATE/ SHEET: GRADE 250 AS 3678
 - PFC: GRADE 300+ AS/NZS 3679.1
 - R/BAR: GRADE 300+ AS/NZS 3679.1
 - ALL FLANGES ANSI 150
 - ALL VALVES FIRE SAFE CARBON STEEL
 2. DESIGN COMPLIANCE
 - ADG CODE 7th EDITION
 - AS1940-2017: STORAGE AND HANDLING OF FLAMMABLE AND COMBUSTIBLE LIQUIDS
 - AS1692-2006: STEEL TANK FOR FLAMMABLE AND COMBUSTIBLE LIQUIDS
 - FUEL TANK IS DEFINED AS CATEGORY 3, WITH COMBUSTIBLE LIQUID
 - BUNDED 'DOUBLE SKIN' DESIGN
- DIMENSIONAL AND MATERIAL SPECIFICATIONS WITHIN FOLLOWING DRAWINGS SET NEED TO BE MAINTAINED AND TO MEET COMPLIANCE
- THE DESIGNED SAFE FILL LEVEL (SFL) IS 2,000L
 - FUEL TANK ASSEMBLY WEIGHT
 - EMPTY: 770kg
 - FILLED: 2,430kg

8mm LIFTING LUG

SPILL BOX

FORKLIFT POCKET

INSPECTION HATCH

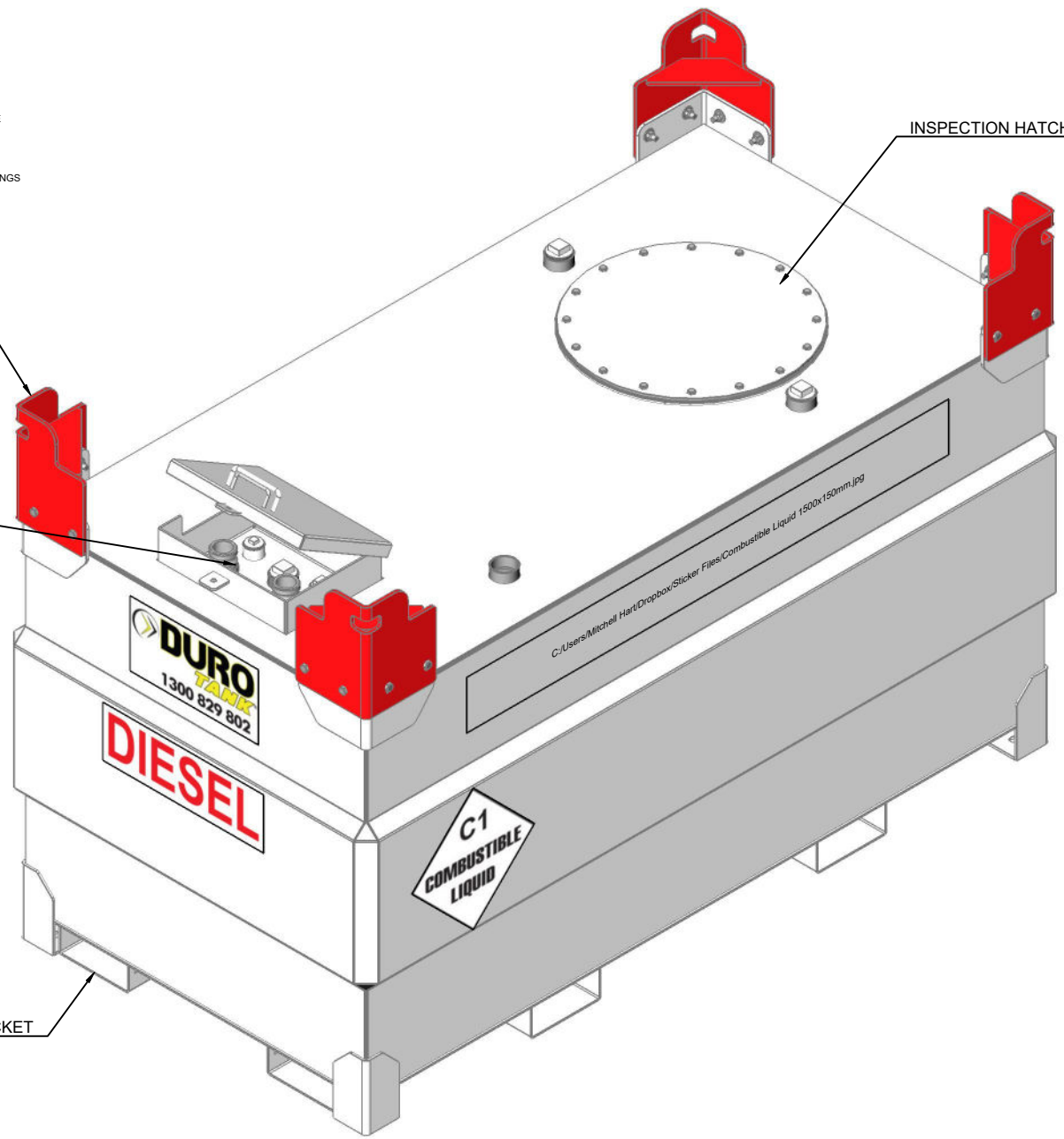

| REV | DATE | DETAILS | BY/APPD |
|------------------|---------|--------------------------|---------|
| A | 29/9/20 | RELEASED FOR MANUFACTURE | MH |
| REVISION HISTORY | | | |

GENERAL NOTES
 ALL DIMENSIONS ARE IN MILLIMETERS (mm) U.N.O
 GENERAL TOLERANCE U.N.O
 X ±0.5
 XX ±0.1
 XXX ±0.05
 Angular ±0.25°
 REMOVE ALL SHARP EDGES AND BURRS
 PAINTING MANUFACTURER IN ACCORDANCE
 MATERIAL GR250

2 West St, Lake Cargelligo NSW 2672
 Phone: 1300 829 802
 Email: sales@durotank.com.au
 Web: www.durotank.com.au



| | | | |
|--------------------------------------|-------------|-------------------|--|
| | | TITLE OVERVIEW | |
| DRN: MWH DATE: 29.09.2020 CHK: | SHEET A3 | DWG NO: | DC020 DO NOT SCALE U.N.O PAGE 02 OF 00 |

1 2 3 4 5 6 7 8 9 10

A
B
C
D
E
F

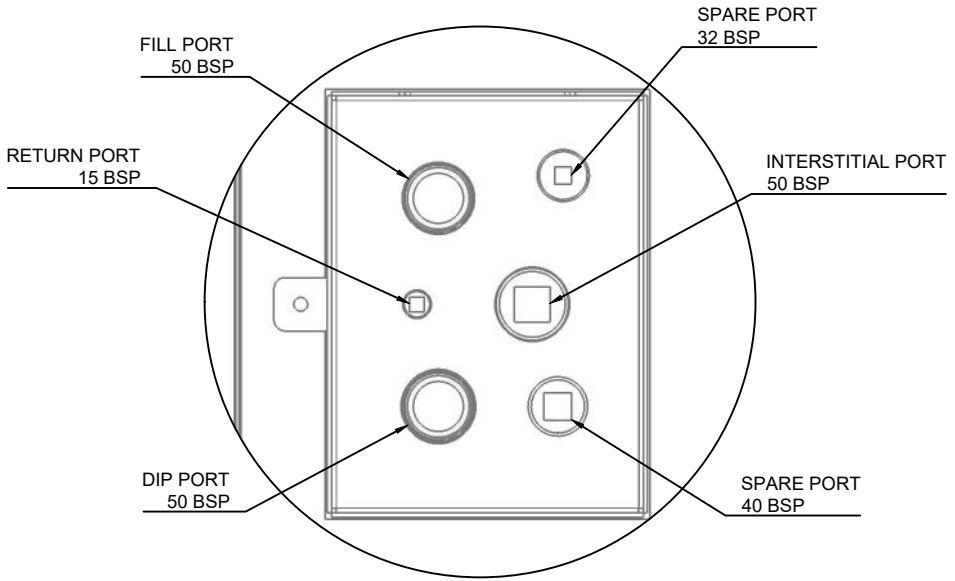

Detail A
Scale 1:5

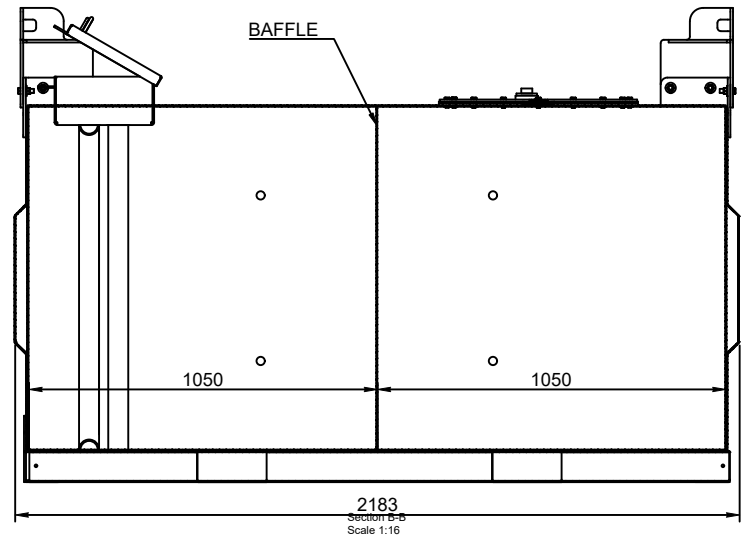
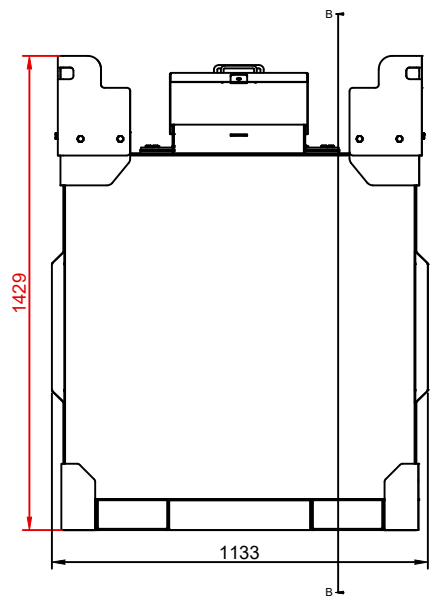
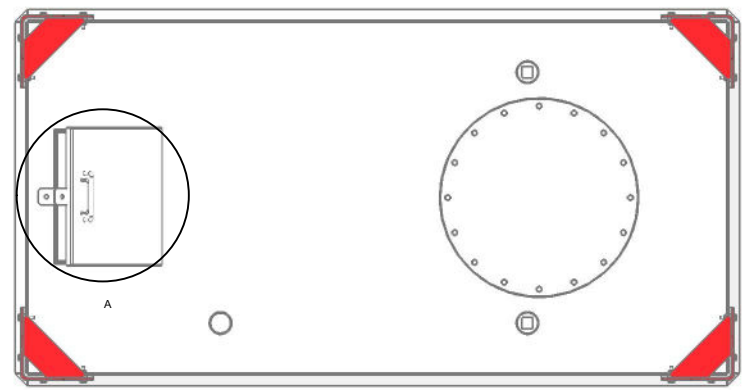

| REV | DATE | DETAILS | BY/APPD |
|------------------|---------|--------------------------|---------|
| A | 29/9/20 | RELEASED FOR MANUFACTURE | MH |
| REVISION HISTORY | | | |

GENERAL NOTES
 ALL DIMENSIONS ARE IN MILLIMETERS (mm) U.N.O.
 GENERAL TOLERANCE U.N.O
 X ±0.5
 X.X ±0.1
 X.XX ±0.05
 Angular ±0.25°
 REMOVE ALL SHARP EDGES AND BURRS
 PAINTING MANUFACTURER IN ACCORDANCE
 MATERIAL GR250

2 West St, Lake Cargelligo NSW 2672
 Phone: 1300 629 802
 Email: sales@durotank.com.au
 Web: www.durotank.com.au



| | | | |
|--------------------------------------|-------------|------------------------|---------------|
| 1/5 STANDARD PRACTICE 1/16 | | TITLE DC020 LAYOUTS | |
| DRN: MWH DATE: 29.09.2020 CHK: | SHEET A3 | DWG NO: DC020 | PAGE 02 OF 02 |

1 2 3 4 5 6 7 8 9 10